

User-centric Real-time System for Building Disaster Alerts

Tae-Hwan Kim,¹ Eun-Su Seo,² and Se-Hyu Choi^{3*}

¹Department of Spatial Information, Kyungpook National University,
41566, 80, University Road, Buk-gu, Daegu, South Korea

²School of Science and Technology Acceleration Engineering, Kyungpook National University,
41566, 80, University Road, Buk-gu, Daegu, South Korea

³School of Architectural, Civil, Environmental and Energy Engineering, Kyungpook National University,
41566, 80, University Road, Buk-gu, Daegu, South Korea

(Received August 8, 2025; accepted November 18, 2025)

Keywords: disaster alert system, indoor evacuation, MEMS sensors, real-time monitoring

As buildings become increasingly complex and aging infrastructures persist in modern cities, the risk of diverse disaster scenarios has grown significantly. To address the safety challenges associated with outdated building environments, we propose a mobile application-based disaster warning and evacuation system tailored for indoor use. The system is built on a custom-designed embedded platform, the Crisis Response Processor (CRP), which utilizes stacked Raspberry Pi boards and MEMS sensors to collect spatial data in real time. It automatically analyzes environmental parameters using predefined thresholds and provides users with disaster alerts and evacuation guidance through a connected mobile interface. Experimental results demonstrated high accuracy (precision 95.9%, recall 97.9%) and practical user responsiveness, confirming the system's applicability for real-world indoor disaster management.

1. Introduction

As modern society advances, the complexity and scale of buildings increase significantly, leading to more diverse and severe disaster risks.^(1,2) With the development of spatial information technologies, a wide array of building-related data is now being collected in real time, raising interest in how big data can be leveraged for disaster management.^(3,4)

In particular, old buildings often lack modern disaster response systems, posing safety concerns during emergencies.^(5,6) In this study, we propose an application-based disaster warning and evacuation service system tailored for indoor environments, especially within aging building structures.^(7,8) In Korea, disaster management and safety are legally regulated under the Framework Act on the Management of Disasters and Safety, which provides the institutional basis for developing indoor alert and evacuation systems.⁽⁹⁾ Our aim is to enable the real-time detection and user notification of disaster situations, along with providing appropriate evacuation guidance.^(4,10)

*Corresponding author: e-mail: shchoi@knu.ac.kr
<https://doi.org/10.18494/SAM5870>

Figure 1(a) shows the entire system. The proposed system utilizes a Crisis Response Processor (CRP), an embedded platform consisting of stacked Raspberry Pi-based custom boards.⁽⁷⁾ Once powered on, the main board automatically initiates the service program, connects to a central server and mobile application, and begins collecting spatial data in real time through MEMS sensors, specifically, accelerometers, gyroscopes, and temperature and humidity sensors.^(11,12) Figure 1(b) shows the final form of the CRP.

On the basis of user-defined thresholds, the system analyzes environmental conditions and issues alerts or evacuation instructions when anomalies are detected.^(13,14) Figure 2(a) shows an alarm below the threshold, and Fig. 2(b) shows an alarm above the threshold. Alarms are triggered by utilizing the application's notification function.

To validate the system's performance, experiments were conducted within the Engineering Building of Kyungpook National University in Daegu, Korea. Figure 3(a) shows the exterior of the Kyungpook National University Engineering Building.

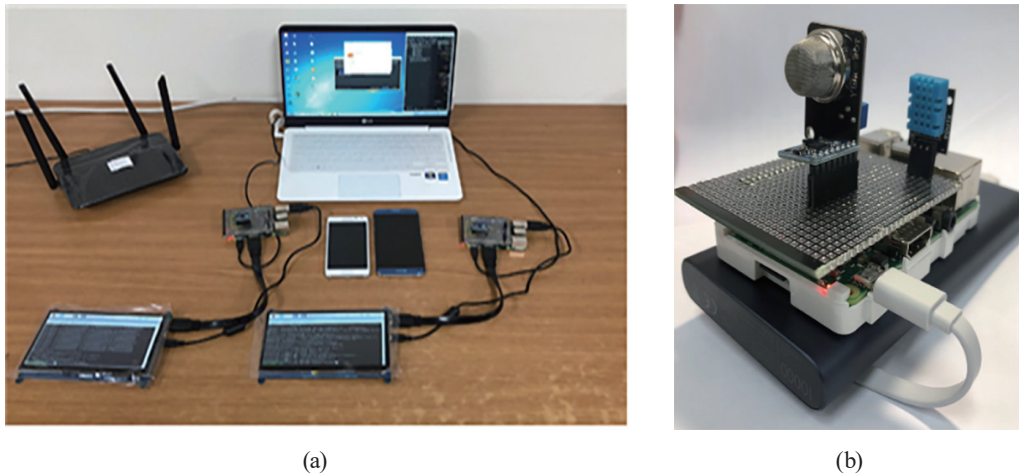

Fig. 1. (Color online) (a) Disaster Information Service Platform (DISP) and (b) CRP.

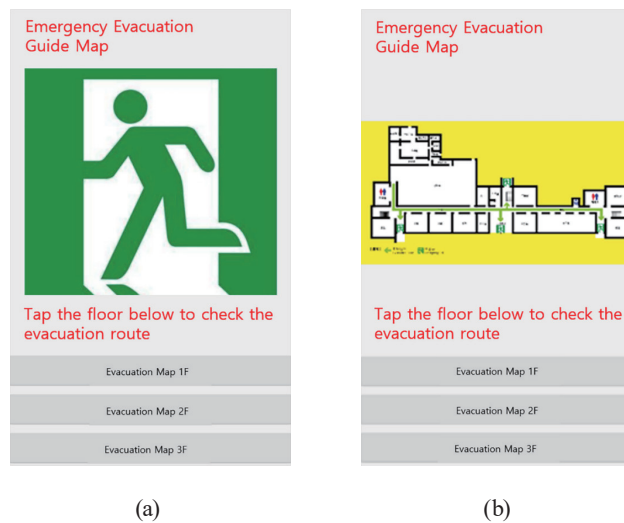

Fig. 2. (Color online) (a) Danger warning and (b) danger evacuation messages.

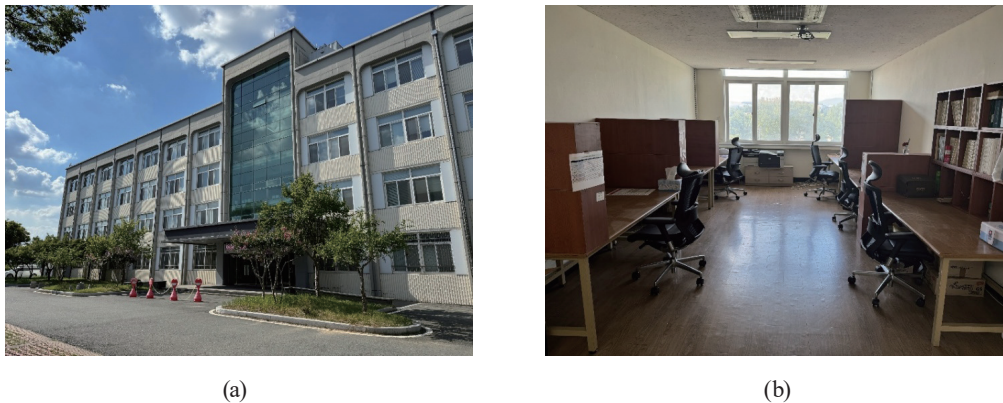

Fig. 3. (Color online) (a) Exterior view of the College of Engineering at Kyungpook National University and (b) indoor space on the second floor where the disaster detection system was installed.

The access point (AP) was installed on the second floor, and the sensor responsiveness was tested vertically from the first to the fourth floor. Figure 3(b) shows one of the internal points where the AP was installed.

2. Data, Materials, and Methods

We developed a mobile application-based disaster warning system for indoor environments, capable of detecting hazardous events such as building collapse, fire, and gas leakage in real time. The system comprises sensor modules, a data processing and communication unit, and a user alert interface. Unlike previous web-based disaster alert systems, the proposed system emphasizes accessibility and responsiveness, particularly in aging building infrastructures.

2.1 Disaster information service system architecture

The proposed system is built on an embedded operating platform tailored for disaster response in indoor spaces. Figure 4(a) shows the actual appearance of the deployed hardware. The core of the system is based on a Raspberry Pi mainboard running a 64-bit Linux OS, which offers high portability, scalability, and system security. A 7 inch capacitive touchscreen display (1024×600 resolution) is connected to the board via HDMI and USB ports, enabling both visual output and user input. To collect spatial information, the board is equipped with several MEMS-based sensors, mounted in a stacked two-layer structure to minimize the hardware footprint, as illustrated in Fig. 4(b). The sensing module includes three types of sensors. First, MPU6050 is a 6DoF sensor that simultaneously measures acceleration and orientation. Second, DHT-11 is used to capture basic ambient conditions, including temperature and humidity. Finally, the system incorporates a suite of nine gas detection modules capable of identifying various substances such as flammable gases, alcohol, methane, LPG, butane, carbon monoxide, hydrogen, and general air pollutants. All sensors are powered at 5 V and operate at 150 mA, and were selected for their low-power consumption and high-efficiency characteristics. A custom SoC-based prototype was implemented to integrate these sensors into the compact platform, facilitating real-world applicability.

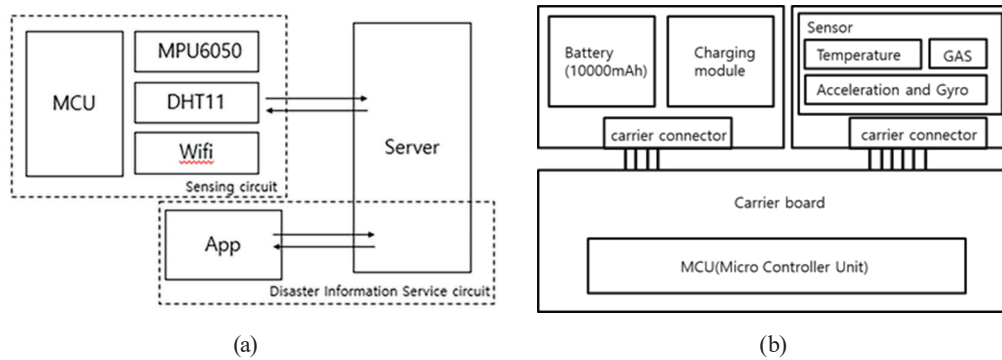

Fig. 4. (a) DISP and (b) CRP configuration diagrams.

2.2 Real-time disaster alert mechanism

To promptly detect and notify users of indoor disaster events, a real-time disaster alert and evacuation guidance system was developed.^(13,14) The system categorizes alerts into two stages, caution and critical, on the basis of user-defined thresholds.^(15,16) When a sensor reading exceeds the caution level, a notification is sent to administrators for inspection. Upon reaching the critical threshold, the system issues immediate alerts to all users and provides evacuation instructions. The system addresses each type of disaster by using specific sensor data and predefined logic. For building collapse detection, the system analyzes data from the MEMS accelerometer and gyroscope. When vibration or tilt values exceed defined thresholds, alerts are delivered in two sequential stages. For fire detection, anomalies in temperature and humidity measured by the DHT-11 sensor trigger a similar two-stage alert mechanism.

Once a disaster alert is activated, the system automatically transmits a floor-specific evacuation map to the user's device. Additionally, users can access the full-building evacuation plan through the mobile application interface.

2.3 System operation algorithm

The system architecture is structured into three layers comprising server initiation, sensor data acquisition, and mobile app communication with user notification. Once power is supplied, Raspberry Pi initializes the program automatically, establishes server and app connections, and starts collecting real-time spatial data. Sensor values are continuously compared with preset thresholds. When anomalies are detected, the system determines whether to issue alerts to users or notify administrators only in borderline cases.

The server maintains both user access logs and sensor status records. Faulty sensor units can be identified remotely, and the cause of the error can be traced using the last transmitted message for debugging.

The mobile application alerts users via notifications and vibration. Notifications appear as system messages similar to SMS or instant messages, and vibration continues until the user acknowledges the alert. Upon confirmation, the app displays a customized evacuation route based on the user's current location and the detected event.

2.4 Comparative system testing

To evaluate the performance of the proposed system, experimental setups were arranged in the Engineering Building at Kyungpook National University. In the first experiment, the proposed application-based system (Model B) was compared with a reconstructed internet-based alert system (Model A), which was based on a previous RSS-based model. Both systems operated under identical environmental and hardware conditions using the same MEMS sensor suite. The internal system workflow is presented in Fig. 5. Four sensors were installed on each floor, and the average response time per floor was measured and recorded. This comparison was designed to assess the differences in system performance and verify the practical efficiency of the proposed mobile application-based approach. The user interface tested in this study is shown in Fig. 6.

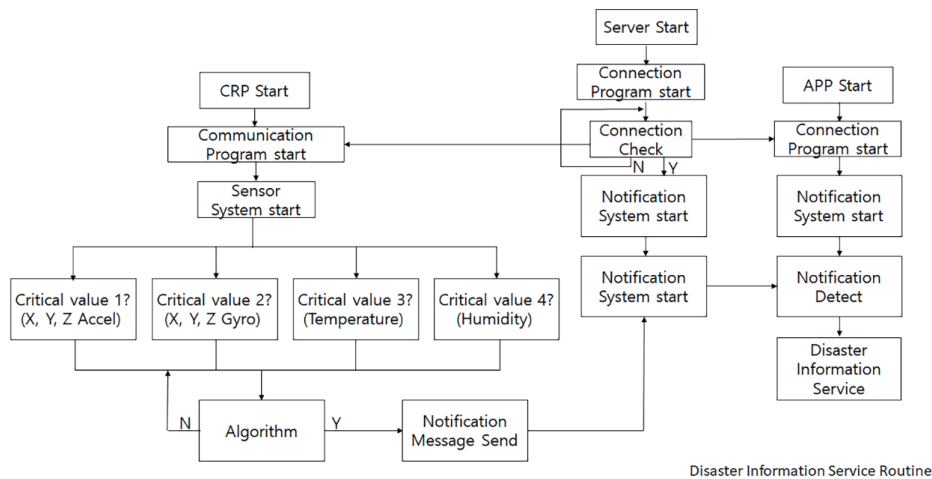

Fig. 5. Disaster information service routine.

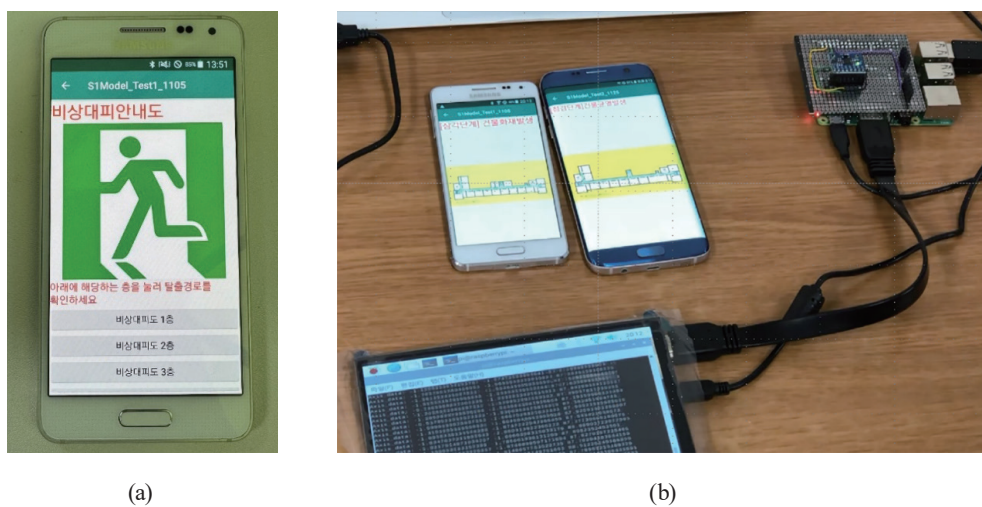

Fig. 6. (Color online) (a) Danger warning message running on mobile phone. (b) Danger evacuation message running on mobile phones.

3. Results

3.1 Comparison of performances of disaster alert systems

The proposed application-based disaster alert system (Model B) demonstrated a significantly shorter response time than the conventional internet-based system (Model A). Model A, implemented as a receiver-customized disaster alert system based on RSS protocols, operated through a web server and browser interface.^(17,18) consistent with the architecture of public alert-and-warning systems described by the U.S. Partnership for Public Warning.⁽¹⁹⁾ In contrast, Model B utilized a 5G Wi-Fi network via a dedicated AP, supporting a data transmission speed of up to 650 Mbps, equivalent to approximately 5200 MB/s, representing a 520% improvement in communication bandwidth over Model A.

The experimental setup involved the two systems equipped with the same MEMS sensor suite: Sensor 1 for acceleration and Sensor 2 for temperature and humidity. Model A was constructed using an Arduino-based platform connected to a web server, with alerts delivered via a browser interface. Tests were conducted across four floors, 1F to 4F, of Engineering Building 2 at Kyungpook National University, using the second floor as the reference point.

Alert messages were formatted as byte-type text strings to minimize payload size and transmission delay. Response times were measured using the internal counter of the respective MCU units. The conventional system (Model A) exhibited an average response time of approximately 1500 ms, while the proposed application-based system (Model B) achieved an average response time of only 5 ms. This corresponds to a 300-fold improvement in alert delivery speed. These results confirm that the proposed system provides significantly enhanced responsiveness and real-time disaster communication performance compared with conventional web-based systems, which require manual user access via browsers and are dependent on external internet infrastructures. The data transmission process across platforms is illustrated in Fig. 7. Table 1 summarizes the measured response time results.

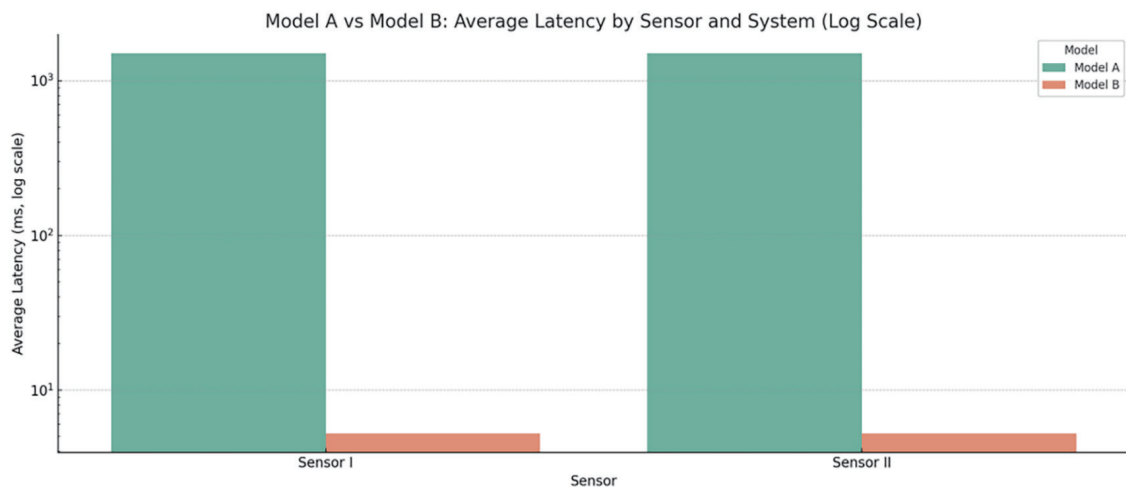

Fig. 7. (Color online) Data flow across platform.

Table 1

Response times of internet-based and application-based systems (Models A and B, respectively).

Model	System	Sensor	1st floor	2nd floor	3rd floor	4th floor
Model A (Internet)	System 1	Sensor I	1500 ms	1400 ms	1500 ms	1600 ms
		Sensor II	1500 ms	1400 ms	1600 ms	1500 ms
	System 2	Sensor I	1400 ms	1500 ms	1600 ms	1500 ms
		Sensor II	1400 ms	1500 ms	1500 ms	1600 ms
Model B (App)	System 1	Sensor I	6 ms	4 ms	5 ms	7 ms
		Sensor II	4 ms	5 ms	6 ms	7 ms
	System 2	Sensor I	5 ms	4 ms	5 ms	6 ms
		Sensor II	5 ms	4 ms	5 ms	6 ms

In previous research, the internet-based system was implemented using a web server and Raspberry Pi-based MEMS sensor modules. Web clients could access disaster status information through browsers; however, the system lacked real-time push notification capability and mobile integration. In contrast, the application-based system supports push notifications, vibration alerts, and offline functionality through local APs, thereby enhancing system robustness in the event of infrastructure failure. A comparison of system features is shown in Table 2.

3.2 User efficacy evaluation

To evaluate the user efficacy of the proposed disaster alert system, a simulated evacuation experiment was conducted in the College of Engineering Building at Kyungpook National University. The experiment took place across four vertically connected floors (1F–4F) under identical indoor lighting and temperature conditions. A total of 48 participants (30 males and 18 females, aged 20–45 years) voluntarily participated in the test. They were divided into four groups of 12 people, each assigned to a different floor. Before each trial, participants were instructed to evacuate immediately upon receiving an alert signal on their mobile devices. The alert was randomly triggered using three system types (internet-based, optical fiber (FBG)-based, and MEMS-based CRP) while maintaining the same network environment and sensor configuration.

Reaction time was defined as the elapsed duration between the alert reception and the initiation of physical movement toward the designated exit. This duration was automatically recorded by the CRP mobile application log, with timestamps synchronized to the server. Each experiment was repeated three times per system type, and the average response time was calculated for each group. All tests were conducted under non-hazardous simulated conditions, and participants provided consent prior to participation. The experiment was designed to verify whether improvements in technical latency could translate into measurable user response efficiency during evacuation. Evacuation response results are presented in Table 3.

The results show that the proposed MEMS-based CRP system reduced total response time by 44% compared with the optical fiber-based model and by 48% compared with the conventional internet-based system. Although the optical fiber-based system offers the lowest physical transmission delay, its centralized alert process results in longer overall user response time. The

Table 2
Comparison of alert delivery features among existing systems.

Feature	Internet-based system	Optical fiber (FBG)-based system	MEMS-based CRP system
Sensor type	Basic thermal/vibration sensors	FBG-AC-310 (1-axis)	MPU6050 (6-axis) + DHT-11
Communication	HTTP (external server)	Fiber-optic cable	Local 5 GHz Wi-Fi
Response time	~1500 ms	<10 ms	<10 ms
Power and cost	Moderate (network-dependent)	Requires optical source (~30 M KRW)	Low-power 5 V / 150 mA per node
Evacuation feedback	Text or broadcast message	Central console only	Mobile app (push + vibration + map)
Deployment	Fixed, wired	Single building only	Portable, multi-site scalable

Table 3
Comparison of user response times among disaster alert systems.

System type	Physical signal delay (ms)	Average user response time (ms)	Alert delivery method	Overall ranking (user reaction speed)
Internet-based system	10–30	1500	External server → web interface	Slowest
Optical fiber-based system	<1	900	Central console → manual broadcast	Medium
MEMS-based CRP system	2–10	5	Direct mobile push + vibration + map	Fastest

MEMS-based CRP system minimizes this delay by sending real-time push notifications directly to users, leading to the fastest total evacuation reaction among the three models.

This performance improvement stems from the combination of local autonomous sensing, instantaneous mobile notifications, and haptic feedback, which shorten the user's reaction delay after alert recognition. Unlike the optical fiber- and internet-based systems, which rely on centralized servers or fixed cabling, the CRP system operates autonomously in local networks, maintaining responsiveness even when external connectivity is unavailable. These findings confirm that the proposed architecture not only improves technical latency but also enhances real-world evacuation efficiency, making it a practical, user-oriented solution for intelligent building safety management.

3.3 System accuracy and reliability evaluation

To evaluate the reliability and operational stability of the proposed MEMS-based disaster alert system, both short-term and long-term experiments were conducted under controlled indoor conditions. The experimental setup and methodology were identical to those used in the user efficacy evaluation described in Sect. 3.2 to ensure comparability between systems. Tests were performed in the College of Engineering, Kyungpook National University, Daegu, Korea, across four vertically connected floors (1F–4F), with a dedicated access point (AP) installed on the second floor to maintain seamless 5 GHz local wireless communication. Sensor nodes were attached to structural columns and corridor walls to monitor vibration, temperature, and gas concentration variations under simulated disaster scenarios.

3.3.1 Experimental procedure

The evaluation consisted of two phases. In the short-term response test, ten controlled events were generated for each disaster type—vibration (simulated structural collapse), heat (fire), and gas leakage—using vibration generators, portable heat sources, and CO simulators. Sensor readings were recorded and classified as true positive, false positive, or false negative to quantify accuracy. In the long-term continuous operation test, the system operated uninterruptedly for 72 h, transmitting data at 20 ms intervals to a central server. All packets were logged to measure data loss and transmission delays. Throughout the test, no packet loss or latency exceeding 50 ms was observed, confirming stable operation in real-world indoor conditions.

3.3.2 Comparison with existing systems

For objective evaluation, the proposed MEMS-based CRP was compared with the following two reference systems:

- (1) the optical fiber-based system previously developed under the 2020-E Smart Monitoring and Evacuation Project for Aging School Buildings and
- (2) the reconstructed conventional internet-based alert system used for comparative testing in this study.

The fiber-optic-based system employed FBG-AC-310 sensors connected via fixed optical cables and a central optical interrogator, whereas the conventional system utilized an HTTP-based server–client communication model dependent on external network connectivity.

In contrast, the proposed CRP system adopted distributed MEMS sensors (MPU6050 and DHT-11) communicating through a local wireless network. The comparison criteria included sensing accuracy, installation complexity, network dependency, and user accessibility (Table 3).

Although all systems successfully delivered alerts, the MEMS-based CRP demonstrated superior responsiveness and deployment flexibility. Unlike the optical- and internet-based systems, which rely on fixed infrastructures or external connectivity, the CRP operated autonomously within a local wireless network and continued functioning even during network outages.

3.3.3 Accuracy and reliability results

The system achieved an average precision of 95.9% and recall of 97.9%, with corresponding false positive and false negative rates of 4.1 and 2.1%, respectively. For gas leakage detection, no false negatives were observed across all test iterations, resulting in a recall rate of approximately 100% (Table 4). This is attributed to the high sensitivity of the gas detection module (CO and flammable gas sensors) under controlled indoor conditions, where concentration variations were large enough to trigger consistent sensor responses.

These results confirm that the proposed CRP system can accurately detect real disaster events while minimizing false alarms. Its stable performance over 72 hours of continuous operation demonstrates strong network reliability and endurance.

Table 4
Reliability evaluation results by disaster type.

Disaster type	True positives	False positives	False negatives	Precision	Recall
Vibration	48	2	1	95.0	97.9
Heat (fire)	45	3	2	93.8	95.7
Gas leakage	50	1	0	98.0	100.0
Average	—	—	—	95.9	97.9

Compared with both the optical fiber-based and conventional internet-based systems, the MEMS-based architecture maintains comparable sensing precision while achieving markedly higher responsiveness, autonomy, and practical scalability.

Therefore, the proposed CRP serves as a validated and deployable successor for real-time disaster alert and evacuation applications in complex indoor environments. The proposed MEMS-based CRP maintained precision above 95% and recall near 98%, demonstrating comparable sensing accuracy to the fiber-based system and significantly improved operational stability over the internet-based model.

4. Discussion

The proposed application-based disaster alert system effectively overcomes several limitations observed in conventional internet-based building alert systems. Primary drawbacks of existing models include limited transmission coverage, dependence on internet connectivity, the lack of push-based notifications, and reduced reliability during communication failure scenarios.

In conventional web-based systems, users are required to manually access browser interfaces after receiving a disaster message, which may not be possible in high-risk or time-critical environments. In contrast, the proposed system operates over a local AP network, ensuring continued functionality even in the absence of external internet connectivity. It enables automatic push notifications, vibration alerts, and multimedia evacuation guidance without requiring user interaction or internet access. This functionality significantly enhances system responsiveness and reliability during emergencies.

The proposed system's real-time sensing capability also enables it to generate disaster messages independently of centralized authority inputs. This local autonomy allows for immediate detection and response based on real-time environmental data collected from the installed sensors.

Unlike earlier systems that primarily relied on text-based messages, the proposed platform provides multimodal alerts including audio announcements, visual guides, and haptic feedback. This multimodal approach enhances message credibility and user responsiveness, consistent with the classic communication and persuasion framework proposed by Hovland and Weiss.⁽²⁰⁾ This multimedia approach aligns with modern requirements for intuitive and user-friendly disaster response systems, supporting two-way communication and context-aware responses.

Transmission latency critically affects multimedia-based alert delivery. The implemented 5G Wi-Fi architecture ensures seamless communication among all sensor nodes with reduced delay. In terms of sensing performance, MPU6050 was selected over FBG-AC-310, a sensor commonly

Table 5
Specifications of MPU6050 MEMS sensor and FBG-AC-310 fiber optic sensor.

Feature	Resolution	Operating temperature	Number of measurement axes	Response time
MPU6050	0.001G	−40 to 85 °C	Axes 6 (3 accel + 3 gyro)	Less than 10 ms
FBG-AC-310	0.01G	−20 to 80 °C	1	Less than 10 ms

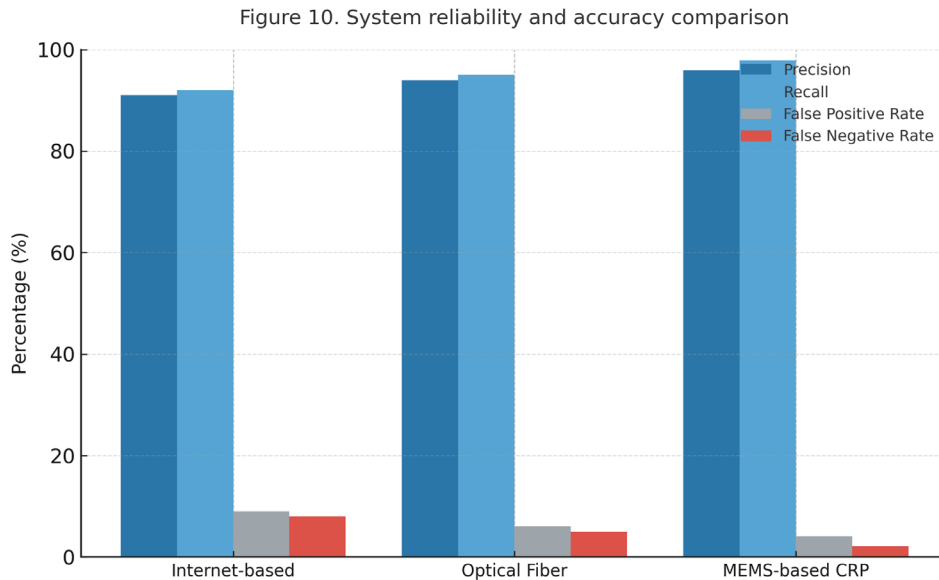

Fig. 8. (Color online) Comparative performance of the conventional internet-based, optical fiber-based, and MEMS-based CRP systems in precision, recall, and error rates.

used in aging buildings in South Korea. MPU6050 provides a resolution of 0.001 G, outperforming FBG-AC-310's 0.01 G by one order of magnitude. Additionally, MPU6050 supports a wider temperature operating range (−40 to 85 °C vs −20 to 80 °C) and offers six-axis measurement capability compared with the single-axis sensing of FBG-AC-310 (Table 5).

All sensor modules exhibited a response time below 10 ms during experimental validation. It was observed that excessively high sensor refresh rates could lead to increased communication load and accelerated battery consumption. This highlights the need to optimize refresh intervals to balance system responsiveness with power efficiency. Figure 8 compares the performance results across system types. In future work, we plan to address this challenge by developing adaptive refresh algorithms that dynamically adjust the sensor update frequency on the basis of environmental context and event severity.

5. Conclusions

In this study, we designed and implemented an application-based disaster warning system for indoor environments, particularly within aging buildings. Unlike conventional disaster response systems that primarily rely on simple fire or human detection, the proposed system is capable of real-time spatial data collection and analysis using embedded MEMS sensors. This allows building administrators and occupants to receive immediate alerts and evacuation guidance based on localized risk analysis.

The major conclusions of this study are summarized as follows. First, in terms of system responsiveness, the application-based disaster warning system achieved a significantly shorter response time of approximately 5 ms compared with 1500 ms for the conventional internet-based system. This indicates a performance improvement by a factor of nearly 300, demonstrating the system's effectiveness for real-time disaster scenarios. Second, the proposed system exhibits strong resilience to network failures. Even when internet connectivity is lost, the system can continue to deliver alerts and evacuation instructions through local device notifications, vibration alerts, and audio signals. This capability effectively overcomes one of the critical limitations of existing network-dependent systems. Third, in the comparison of sensor efficiency and cost, the MEMS-based system using the MPU6050 sensor showed a higher resolution and a wider operating temperature range than the fiber optic sensor commonly used in aging infrastructure.

Furthermore, the MEMS-based platform is far more cost-effective, as approximately 20 MEMS sensor units can be installed for the cost of a single fiber optic sensor, which also requires a dedicated light source generator valued at approximately 30 million Korean won. These advantages make the proposed system highly suitable for large-scale deployment in practical settings. Consequently, the presented system can serve as a prototype framework for indoor disaster response platforms and provide a foundational model for future spatial-information-based safety applications.

Acknowledgments

This research was supported by the Project for Practical Use of Regional Science and Technology Performance of the Commercialization Promotion Agency for R&D Outcomes (COMPA) funded by the Ministry of Science & ICT (grant number: RS-2022-CP000143, Kyungpook National University).

References

- 1 D. S. Mileti and J. H. Sorensen: *Landslides* **1** (1990) 17. <https://doi.org/10.1007/BF02590156>
- 2 Y. Yin, Y. Sun, and H. Wang: *Future Gener. Comput. Syst.* **94** (2019) 600. <https://doi.org/10.1016/j.future.2018.11.008>
- 3 M. A. Kabir, A. S. M. Kayes, and S. K. Gupta: *IEEE Access* **9** (2021) 124425. <https://doi.org/10.1109/ACCESS.2021.3109816>
- 4 H. R. Rao, S. S. Upadhyaya, and J. B. Ramesh: *ACM Trans. Manage. Inf. Syst.* **1** (2010) 1. <https://doi.org/10.1145/1877725.1877727>
- 5 J. H. Sorensen: *Int. J. Mass Emerg. Disasters* **22** (2004) 55.
- 6 M. A. Matin, K. Ozaki, D. Akai, K. Sawada, and M. Ishida: *Proc. 2012 IEEE 62nd Electron. Compon. Technol. Conf. (IEEE, 2012)* 356–357.
- 7 K. Umino, M. Habara, and K. Toko: *Sens. Mater.* **24** (2012) 1. <https://doi.org/10.18494/SAM.2012.764>
- 8 K. Ueno, K. Suzuki, and S. Mori: *Sens. Mater.* **31** (2019) 307. <https://doi.org/10.18494/SAM.2019.2111>
- 9 Korea Ministry of Government Legislation: *Framework Act on the Management of Disasters and Safety*. <http://www.law.go.kr> (accessed July 2025).
- 10 J. M. Mendonça, A. P. Matos, and J. F. de Souza: *J. Ambient Intell. Humaniz. Comput.* **13** (2022) 5857. <https://doi.org/10.1007/s12652-021-03241-2>
- 11 M. Gautam, S. Khadka, and D. Wagle: *Int. J. Disaster Risk Reduct.* **85** (2023) 103486. <https://doi.org/10.1016/j.ijdrr.2022.103486>
- 12 J. H. Kim, H. Lee, and S. H. Choi: *Sensors* **21** (2021) 5587. <https://doi.org/10.3390/s21165587>

- 13 J. Park, Y. Kim, and D. H. Lee: IEEE Internet Things J. **9** (2022) 17327. <https://doi.org/10.1109/IJOT.2022.3185030>
- 14 OASIS: Common Alerting Protocol v1.2. <https://docs.oasis-open.org/emergency/cap/v1.2/> (accessed July 2025).
- 15 Korea Information and Communication Technology Association: TTA.KO-06.0364 (2014).
- 16 Korea Information and Communication Technology Association: KCS.KO-06.0263 (2012).
- 17 Korea Meteorological Administration (KMA): https://www.kma.go.kr/weather/lifenindustry/sevice_rss.jsp (accessed July 2025).
- 18 U.S. National Oceanic and Atmospheric Administration (NOAA): <https://www.nws.noaa.gov/rss/> (accessed July 2025).
- 19 Partnership for Public Warning: Protecting America's Communities: An Introduction to Public Alert and Warning Policy and Capability. <https://www.partnershipforpublicwarning.org> (accessed July 2025).
- 20 C. I. Hovland and W. Weiss: Communication and Persuasion (Yale Univ. Press, New Haven, 1953).

About the Authors



Tae-Hwan Kim received his bachelor's degree from Daegu University in 2018 and his master's degree from Kyungpook National University in 2021. Since 2021, he has been pursuing his doctorate at Kyungpook National University. His research interests include AI, MEMS, and spatial information. (taehwan.417@knu.ac.kr)



Eun-Su Seo received his B.S. degree from Kyungpook National University, Korea, in 2010, and his M.S. and Ph.D. degrees from Kyungpook National University, Korea, in 2013 and 2016, respectively. Since 2022, he has been a research professor at Kyungpook National University, Korea. His research interests are in digital twin, disaster prevention, and acceleration. (esseo@knu.ac.kr)



Se-Hyu Choi received his B.S. degree from Kyungpook National University, Korea, in 1990, and his M.S. and Ph.D. degrees from Kyungpook National University, Korea, in 1995 and 2000, respectively. Since 2004, he has been a professor at Kyungpook National University, Korea. His research interests are in AI, disaster prevention, and sensors. (shchoi@knu.ac.kr)