

S & M 0765

Gas-Sensing Properties of Tin Oxide-Based Volatile Organic Compound Sensors for Total Volatile Organic Compound Gases

Toshio Itoh*, Ichiro Matsubara, Masahiro Kadosaki¹,
Yuichi Sakai¹, Woosuck Shin, Noriya Izu and Maiko Nishibori

National Institute of Advanced Industrial Science and Technology (AIST),
Shimo-Shidami, Moriyama-ku, Nagoya 463-8560, Japan

¹Toyama Industrial Technology Center, 383 Takada, Toyama 930-0866, Japan

(Received January 15, 2009; accepted May 16, 2009)

Key words: gas sensor, tin oxide, volatile organic compound (VOC), total volatile organic compound (T-VOC), T-VOC test gas

This study is an investigation on the total volatile organic compound (T-VOC) gas-sensing properties of platinum-added tin oxide (Pt/SnO₂) thick films. We have prepared a T-VOC test gas on the basis of analytical data of the actual indoor air condition of Japanese residences. The T-VOC test gas has 16 components, which belong to 6 groups, namely, aldehydes, aliphatic compounds, aromatic compounds, terpenes, esters, and alcohols. Pt/SnO₂ possesses a good potential for T-VOC gas detection. We discuss the contribution ratios of each group in the T-VOC test gas for the sensor response of the Pt/SnO₂ thick films. The responses of the Pt/SnO₂ thick film are not dominated by parts of the groups, but depend on all the groups in the T-VOC test gas.

1. Introduction

Sick building syndrome is caused by the presence of volatile organic compounds (VOCs) even at low concentrations, i.e., at ppb level. In new houses, room air has high concentrations of VOCs because the building materials include several harmful chemicals, such as residual solvents in plywood, plastics, and bonding agents.^(1–3) The diffusion of VOCs from the building materials decreases over time. However, the concentration of VOCs depends on the lifestyle of the residents, such as the use of electrical appliances, furniture, pesticides, and cosmetics. It is, therefore, important to monitor the concentration of harmful VOCs continuously for human health. Recently, the use of very harmful chemicals, e.g., formaldehyde, has been restricted, but alternative chemicals, whose risks to human health are poorly understood, tend to be used instead. Therefore, it is desirable that we use not only highly selective VOC sensors but also those that can detect all VOCs, i.e., a total volatile organic compound (T-VOC) sensor. The Ministry of Health, Labour and Welfare in Japan has stipulated a provisional regulation for T-VOC concentration in indoor room air, 400 µg/m³.⁽⁴⁾

*Corresponding author: e-mail: itoh-toshio@aist.go.jp

The gas sensing properties for important VOCs, such as, formaldehyde,^(5,6) alcohol,^(7,8) toluene,^(9,10) and several groups of gases, have already been reported.^(11,12) Moreover, we previously reported the responses of 4 metal oxide (SnO_2 , In_2O_3 , WO_3 , and ZnO) thick films to 37 types of VOCs.^(13,14) It is necessary that T-VOC sensors are developed as high-performance gas sensors that can detect several VOC groups. All thick films showed a lower response to aliphatic hydrocarbon gases than to other groups of VOCs. As a result of the addition of 0.5 wt% platinum as a catalyst to the tin oxide thick film, the sensing properties of the platinum-added tin oxide (Pt/SnO_2) thick films for the aliphatic hydrocarbon gases improved.^(13,14) However, the sensing properties of metal-oxide-type gas sensors for mixed gas adjusted at the mixture ratio of indoor room air, i.e., T-VOC gas, have not been thoroughly studied. The metal-oxide-type gas sensors should be confirmed to show a sufficient response to the mixed gas close to the ratio of indoor room air for use as T-VOC sensors.

In this study, we investigate the sensing properties of the Pt/SnO_2 thick films for T-VOC gas. We have prepared a T-VOC test gas on the basis of analytical data of the actual indoor air condition of Japanese residences.⁽¹⁵⁾ We report the sensing properties of the Pt/SnO_2 thick films in relation to the provisionally regulated T-VOC concentration, and the contribution ratios of each group in the T-VOC test gas in the response of the Pt/SnO_2 -type sensors.

2. Experimental

2.1 Preparation of T-VOC test gas

The molar ratio of each VOC component in the T-VOC test gas was determined on the basis of chemical analysis data on the indoor air condition of Japanese residences, which was reported by Osawa *et al.*⁽¹⁵⁾ Table 1 shows the concentrations and groups of each VOC component in the T-VOC test gas (Sumitomo Seika Chemicals). The balance gas of the T-VOC test gas was nitrogen. The total concentration of the T-VOC test gas was 7.80 ppm, i.e., $3.71 \times 10^4 \mu\text{g/m}^3$.

2.2 Synthesis of Pt/SnO_2 thick films as T-VOC sensors

A platinum colloid suspension (Toda Kogyo Corp.) was added to the SnO_2 powder (C.I. Kasei NanoTec; std. particle size: 20–30 nm). The amount of platinum was 0.5 wt% relative to the SnO_2 . The mixture was stirred, dried, and then calcined at 600°C for 1 h. The resulting Pt-added SnO_2 powder was ground and dropped into Tanaka Kikinzoku TMS-106 vehicle for the preparation of Pt-added SnO_2 paste. The amount of Pt-added SnO_2 powder was 60 wt% relative to the paste. The T-VOC gas sensor elements were prepared by a screen printing method. The paste was printed on alumina substrates with a pair of gold parallel electrodes whose gap is 0.5 mm. The Pt/SnO_2 -printed substrates were calcined at 600°C for 1 h. Figure 1 shows the Pt/SnO_2 sensor element.

2.3 T-VOC sensing properties

The T-VOC sensing properties of the elements were measured using a flow-type

Table 1
Concentrations and groups of each component in the T-VOC test gas.

Component	Concentration [ppm]	Group
Acetaldehyde	1.26	Aldehydes
Propionaldehyde	0.140	Aldehydes
<i>n</i> -Hexene	0.220	Aliphatic Compounds
<i>n</i> -Heptane	0.380	Aliphatic Compounds
<i>n</i> -Octane	0.45	Aliphatic Compounds
<i>n</i> -Nonane	0.84	Aliphatic Compounds
<i>n</i> -Decane	0.85	Aliphatic Compounds
<i>n</i> -Undecane	0.76	Aliphatic Compounds
Benzene	0.189	Aromatic Compounds
Toluene	0.48	Aromatic Compounds
Ethylbenzene	0.171	Aromatic Compounds
<i>m</i> -Xylene	0.60	Aromatic Compounds
1,2,4-Trimethylbenzene	0.57	Aromatic Compounds
Limonene	0.140	Terpenes
Butyl acetate	0.52	Esters
1-Butanol	0.33	Alcohols
Total	7.80*	

*7.80 [ppm] = 3.71×10^4 [$\mu\text{g}/\text{m}^3$]

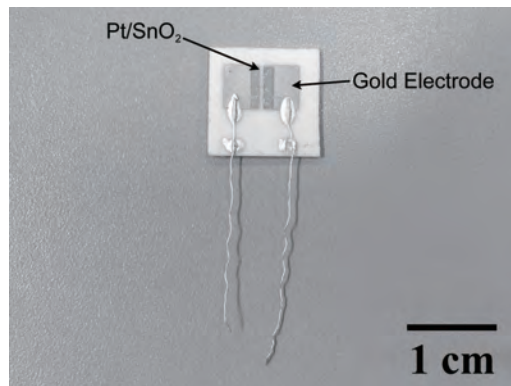

Fig. 1. Image of Pt/SnO₂ sensor element.

apparatus, as shown in Fig. 2. The elements were placed in the chamber heated at 300°C. The original T-VOC test gas (3.71×10^4 $\mu\text{g}/\text{m}^3$) was diluted with pure air to below 1000 $\mu\text{g}/\text{m}^3$. The concentrations of the T-VOC test gas were precisely controlled using mass flow controllers. The total flow was always 200 mL/min. The sensor response is defined using eq. (1),

$$S = \frac{R_a}{R_g}, \quad (1)$$

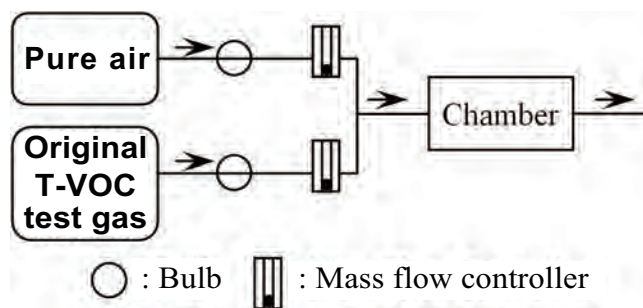

Fig. 2. Depiction of flow apparatus.

where S , R_a , and R_g denote the sensor response magnitude, resistance in pure air, and resistance in the T-VOC test gas, respectively.

3. Results and Discussion

3.1 Sensing properties of Pt/SnO₂

The dynamic resistance responses of Pt/SnO₂ for increasing and decreasing T-VOC concentration between 0 and 1000 $\mu\text{g}/\text{m}^3$ are shown in Fig. 3. The resistance of the Pt/SnO₂ element decreased when the concentration of the T-VOC test gas was increased, and almost reached saturation values at 20 min. It is found that the Pt/SnO₂ exhibits distinct responses in the measured concentration range. The resistance of the Pt/SnO₂ element increased quickly when the concentration of the T-VOC test gas was decreased. The response time (t_{90}), defined as the time taken for the sensor response to reach 90% of its saturation during the T-VOC concentration increase, of the Pt/SnO₂ element was 1.9 min when the concentration of the T-VOC test gas increased to the provisionally regulated value of 400 $\mu\text{g}/\text{m}^3$. The resistance values during T-VOC concentration decrease were almost equal to those during the T-VOC concentration increase. Moreover, the recovery time (t_{10}), defined as the time taken for the sensor response to reach 10% of its saturation during the T-VOC concentration decrease, was also quick, 3.1 min, when the concentration of the T-VOC test gas decreased from the provisionally regulated test gas to 200 $\mu\text{g}/\text{m}^3$. That is, the sensing property of the Pt/SnO₂ was not degraded by any of the T-VOC test gas components.

The inset of Fig. 3 shows the response (S) vs T-VOC test gas concentration of the Pt/SnO₂ element during the T-VOC concentration decrease. The S values were proportional to the concentrations of the T-VOC test gas at less than 1000 $\mu\text{g}/\text{m}^3$. Therefore, the Pt/SnO₂ can be used to accurately detect the T-VOC test gas at approximately the provisionally regulated concentration of 400 $\mu\text{g}/\text{m}^3$. The Pt/SnO₂ element possesses good potential for use in a T-VOC sensor for monitoring indoor room air.

3.2 Contribution ratio of each group for sensor response

The Pt/SnO₂ showed excellent sensing properties for the T-VOC test gas based on the indoor air condition of Japanese residences. The Pt/SnO₂ is, therefore, one of the

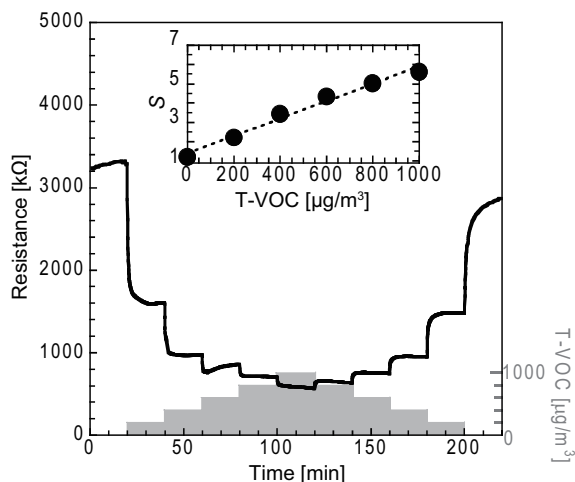

Fig. 3. Resistance profile of Pt/SnO₂ for several concentrations of T-VOC gas. Inset is response magnitude (S) for several concentrations of T-VOC gas.

candidates for the T-VOC gas sensors. However, room air conditions are not always similar to the T-VOC test gas. The T-VOC sensing properties of the Pt/SnO₂ element should be applicable to various room air conditions to some degree. Osawa *et al.* have reported that the room air of recently built houses has a lower concentration of restricted harmful chemicals than that of old houses, but alternative organic species belonging to the same groups of restricted chemicals are detected.⁽¹⁻³⁾ Therefore, we discuss the contribution ratios of each group in the T-VOC test gas for the sensor response of the Pt/SnO₂ on the basis of the validity of T-VOC test gas. The contribution ratio (T) is defined as eq. (2),

$$T_j = \frac{C_j S_j}{\sum C S}, \quad (2)$$

where T_j , C_j , and S_j denote the contribution ratio of each group, concentration of each group included in the T-VOC test gas, and sensor response magnitude to 1 ppm of each group, respectively. Namely, T_j is the percentage on each group of the product of C_j and S_j . This means that the group possessing a larger T_j is more predominant in the sensor response to the T-VOC test gas.

Figure 4 shows the concentrations of each group in the T-VOC test gas. The T-VOC components belonging to the aldehydes were acetaldehyde and propionaldehyde, as shown in Table 1. The concentration of the aldehydes, as shown in Fig. 4, was equal to the sum of the acetaldehyde and propionaldehyde concentrations in the T-VOC test gas. The concentration of the aliphatic compounds was the sum of *n*-hexane, *n*-heptane,

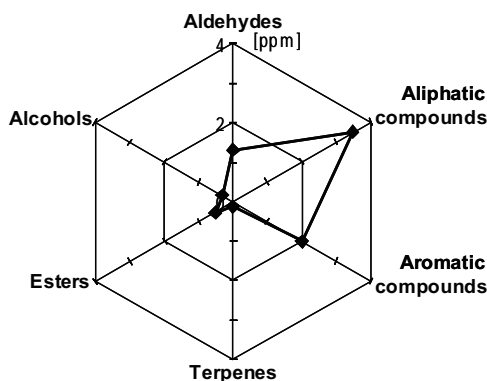

Fig. 4. Concentrations of each group in the T-VOC gas.

n-octane, *n*-nonane, *n*-decane, and *n*-undecane concentrations. In addition, the concentration of the aromatic compounds was the sum of benzene, toluene, ethylbenzene, *m*-xylene, and 1,2,4-trimethylbenzene concentrations. The concentrations of terpenes, esters, and alcohols were equal to the concentrations of limonene, butyl acetate, and 1-butanol, respectively, because the VOC components belonging to these groups were only one in the T-VOC test gas. Therefore, the concentrations of terpenes, esters, and alcohols were lower than those of the other groups.

Figure 5 shows the sensor response magnitudes of the Pt-added SnO₂-type T-VOC sensor to 1 ppm representative species of each group. These VOCs belong to six groups included in the T-VOC test gas. The response magnitudes of the Pt/SnO₂ to 1-propanol, limonene, and butyl acetate were higher than those to acetaldehyde, *n*-heptane, and toluene. We have reported that the sensing properties of the SnO₂-type sensors depend on the types of groups of target gases.⁽¹⁵⁾ Concerning the contribution ratios, the response magnitude of Pt/SnO₂ to each component of aldehydes, aliphatic compounds, and aromatic compounds can be regarded as equal to those to acetaldehyde, *n*-heptane, and toluene, respectively.

Figure 6 shows the contribution ratio of each group in the T-VOC test gas for the responses of the Pt/SnO₂-type T-VOC sensor. The alcohols, which consist of only 1-propanol, gave the largest contribution to the response of the Pt/SnO₂ to the T-VOC test gas, because the Pt/SnO₂ showed the strongest response to 1 ppm 1-propanol. The terpenes and esters, which consist of only limonene and butyl acetate, respectively, had substantial contribution ratios. The aldehydes, aliphatic compounds, and aromatic compounds also had substantial contribution ratios, because the response magnitudes of the Pt/SnO₂ thick film to these groups were low but the concentrations of these groups in the T-VOC test gas are high. Thus, the sensing properties of the Pt/SnO₂ were not dominated by parts of the groups, but depended on all the groups in the T-VOC test gas. Therefore, it was confirmed that the Pt/SnO₂-type T-VOC sensors should be effective for monitoring indoor air condition.

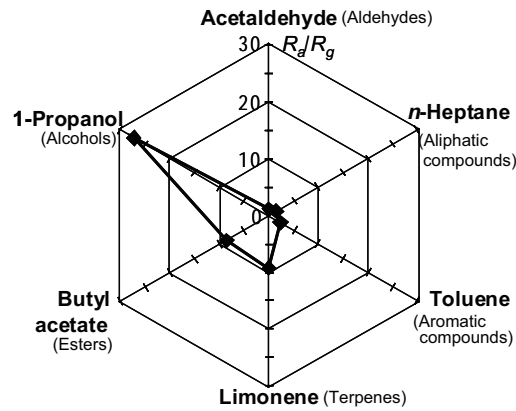

Fig. 5. Sensor response magnitudes of Pt-added SnO_2 -type T-VOC sensor to 1 ppm representative species of each group.

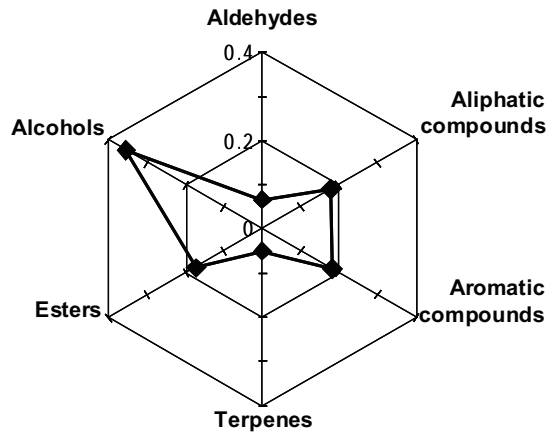

Fig. 6. Contribution ratio (T) of each group in T-VOC gas for responses of the Pt/ SnO_2 -type T-VOC sensor.

4. Conclusions

The resistance of the Pt/ SnO_2 thick film element decreased and increased when the concentration of the T-VOC gas was increased and decreased between 0 and $1000 \mu\text{g}/\text{m}^3$, respectively. The sensor response values are proportional to the concentrations of the T-VOC test gas. The Pt/ SnO_2 can be used to accurately detect T-VOC gas around the provisionally regulated T-VOC concentration, $400 \mu\text{g}/\text{m}^3$. The Pt/ SnO_2 possesses a good

potential for T-VOC gas detection. On the basis of the contribution ratios, the sensing properties of the Pt/SnO₂ thick film elements are not dominated by parts of the groups, but depend on all the groups in the T-VOC gas.

Acknowledgments

We express our sincere thanks to Dr. H. Osawa of the Building Research Institute for providing information on the indoor air condition of Japanese residences. This work was supported by New Energy and Industrial Technology Development Organization (NEDO).

References

- 1 H. Osawa, T. Mitamura, H. Miura and Y. Kuwasawa: Annual Meeting of the Society of Heating, Air-Conditioning and Sanitary Engineers of Japan (2006) p. 1217 (in Japanese).
- 2 T. Mitamura, H. Osawa, H. Miura and Y. Kuwasawa: Annual Meeting of the Society of Heating, Air-Conditioning and Sanitary Engineers of Japan (2006) p. 1221 (in Japanese).
- 3 T. Mitamura, H. Osawa, H. Miura, Y. Kuwasawa, H. Kagawa and A. Ozaki: Annual Meeting of the Society of Heating, Air-Conditioning and Sanitary Engineers of Japan (2007) p. 473 (in Japanese).
- 4 The Ministry of Health, Labour and Welfare in Japan; website: <http://www.mhlw.go.jp/houdou/0107/h0724-1.html> (2001) (in Japanese).
- 5 T. Itoh, I. Matsubara, W. Shin, N. Izu and M. Nishibori: *Sens. Actuators, B* **128** (2008) 512.
- 6 T. Itoh, J. Wang, I. Matsubara, W. Shin, N. Izu, M. Nishibori and N. Murayama: *Mater. Lett.* **62** (2008) 3021.
- 7 M. Vrnata, V. Myslik, F. Vyslouzil, M. Jelinek, J. Lancok and J. Zemek: *Sens. Actuators, B* **71** (2000) 24.
- 8 J. Xua, J. Hanb, Y. Zhang, Y. Sunc and B. Xie: *Sens. Actuators, B* **132** (2008) 334.
- 9 K. Kawamura, M. Vestergaard, M. Ishiyama, N. Nagatani, T. Hashiba and E. Tamiya: *Measurement* **39** (2006) 490.
- 10 J. J. Vijaya, L. J. Kennedy, G. Sekaran and K. S. Nagaraja: *Mater. Lett.* **61** (2007) 5213.
- 11 G. N. Tchoupo and A. Guiseppi-Elie: *Sens. Actuators, B* **110** (2005) 81.
- 12 T. Ceyhan, A. Altindal, M. K. Erbil and O. Bekaroglu: *Polyhedron*, **25** (2006) 737.
- 13 M. Kadosaki, Y. Sakai, I. Tamura, I. Matsubara and T. Itoh: *Elec. Commun. Jpn.* (in press).
- 14 M. Kadosaki, Y. Sakai, I. Tamura, I. Matsubara and T. Itoh: *IEEJ Trans. SM*, **128** (2008) 125 (in Japanese).
- 15 Dr. H. Osawa, private communication (2004).